

专利证书 PATENT CERTIFICATE



深圳市工腾科技有限公司
Shenzhen Gongteng Technology Co., Ltd.

深圳市宝安区福永街道白石厦东区美华路68号
电话: 0755-27398203 传真: 0755-29086674
邮箱: 1917829977@qq.com
www.gongtengkeji.com



GT-ZS2535

蒸汽热收缩包装机 Steam Heat Shrink Packaging Machine



以工匠精神追逐科技飞腾

Pursuing Science And Technology Development By Craftsmanship Spirit

公司简介

COMPANY PROFILE



深圳市工腾科技有限公司地处中国改革开放前沿城市，依托科技城市优良的研发环境，严格执行一线城市高端的企业管理标准，秉承“以工匠精神追逐科技飞腾”的经营理念，从事自动化工业机械、电子产品的研发、设计、销售。业务覆盖：包装工业产品、清洗工业产品、水处理工业产品、消费类机械电子产品等领域，荣获多项国家专利。

我公司设计制造的专业级包装蒸汽收缩机、热风热缩机、套标机，贴标机、封箱机、开箱机、自动化包装生产线、多功能洗桶机、工业级刷桶机、移动式露营空调、船舶海水淡化设备、远洋轮船清护机器人等多项产品处于行业领先水平，赢得了广大客户的信赖，业务基本遍及全国所有省份，并出口至美国、英国、日本、欧洲等西方发达国家，诸多国内一线品牌与国际 500 强企业与我公司进行过业务合作。

公司成立于 2008 年，凭借高端的技术与服务，2009 年成为立白集团供应商，2010 年我公司的设备参与了南非世界杯大喇叭“鸣啦啦”的生产，后续与日化巨头宝洁集团、旺旺集团、日本日塑集团、亚太集团、白猫集团、彩虹集团、传化集团、名臣集团、英国伦敦杜蕾斯集团、迪士尼授权品牌、漫威授权品牌、威露士集团、李锦记集团、北京紫禁城化学研究院、深圳大学、中国印钞造币总公司、空军总院等诸多国内外一线品牌企业建立业务关系。

我公司将继续努力，珍惜昨日的荣誉，接受今日的挑战，再创明天的辉煌！

Shenzhen Gongteng Technology Co., Ltd. is located in the frontier city of China's reform and opening-up. Based on the favorable R&D environment of science and technology city, the Company strictly implements the standards of high-end enterprise management for Tier 1 city, and takes over the operating concept of "pursuing science and technology development by craftsmanship spirit" to work on R&D, design and sales of the mechanical and electronic products of automotive industries. Business range: The business covers packaging industry product, cleaning industry product, water treatment industry product and consumer machinery and electronics product, etc. The Company has been awarded with multiple national patents.

The professional package steam shrinker, heat wind thermoforming machine, shrink sleeve labeling machine, labeling machine, carton sealing machine, automatic packaging production line, multifunctional barrel washer, industrial-grade barrel brushing machine, movable air conditioner for camping, on-board sea water desalination equipment, cleaning robot for ocean steamer and other products designed and manufactured by the Company are dominant in the industry, and they have won the trust of general customers. The business of the Company has covered all the provinces in China, and the products of the Company are exported to developed western countries of USA, UK, Europe and Japan. The Company also cooperates with multiple Tier 1 brands in China and top 500 enterprises in the world for business.

The Company was established in 2008. With high-end technologies and services, in 2009, the Company became a supplier of Liby Group. In 2010, the equipment of the Company participated in the production of "WooLaLa", typhon of South Africa World Cup. Successively, the Company has established business cooperation with Tier 1 brands and enterprises in China, such as P&G (a tycoon of daily chemical), Want Want Group, Techno Group, Asipac Group, Whitecat Group, Rainbow Group, Transfar Group, Mingchen Group, Durex, Disney licensing brand, Marvel licensing brand, Walch, Lee Kum Kee, Forbidden City Chemical Research Institute, Shenzhen University, China Banknote Printing And Minting Corporation General Hospital of Air Force, etc.

The Company will keep trying, cherish the honors of the past, accept current challenges and create glories in the future again!

GT-ZS2535蒸汽热收缩包装机

GT-ZS2535 steam heat shrinkable packaging machine

GT-ZS2535蒸汽热收缩包装机具备蒸汽输出数控调节与自动稳定系统，并且可以对蒸汽温度进行数控调节，属于高端收缩包装设备应用于要求较高的收缩膜外包装生产工艺，可单机使用，也可以搭配自动套标设备组合应用，适用于糖酒饮料、日用化工以及其他工业、农业产品的瓶类、罐类产品的收缩膜外包装加工生产。设备配置内置蒸汽发生器、链接水电即可工作，并设置由外接蒸汽接口，方便用户连接自有蒸汽源使用。整机性能先进、设计成熟，厂方积累了大量的工程案例与工艺经验，可帮助用户解决各类收缩包装生产中的难题。

Gt-zs2535 steam heat shrinkable packaging machine is equipped with steam output numerical control regulation and automatic stability system, and can numerically regulate steam temperature. It is a high-end shrinkable packaging equipment. It is applied to the production process of shrinkable film outer packaging with high requirements. It can be used alone or combined with automatic labeling equipment. It is suitable for sugar and wine drinks, daily chemical industry and other industries Processing and production of shrink film outer packaging of bottles and cans of agricultural products. The equipment is equipped with a built-in steam generator, which can work by connecting water and electricity, and an external steam interface is set to facilitate users to connect their own steam source. With advanced performance and mature design, the manufacturer has accumulated a large number of engineering cases and process experience, which can help users solve the problems in the production of various shrink packaging.



技术参数

TECHNICAL PARAMETERS

GT- ZS2535 蒸汽热收缩包装机

Gt-ZS2535 Steam Heat Shrink Packaging Machine

型号 Model	GT- ZS2535	功率 Power	0-50KW
规格 Specifications	L3000mm x W850mm x H1900MM	重量 Weight	500KG
电压 Voltage	380V 50HZ	耗水量 Water Consumption	40L/H
工作压力 Working Pressure	常压，不蓄压工作模式 Normal Pressure, Working Mode With No Stored Pressure	工作温度 Working Temperature	100-150度
效率 Efficiency	100 - 10000个/H (依据不同产品生产速度不同) 100- 10000 Pieces/hour (Varying In Accordance With The Production Speed Of Different Products)		

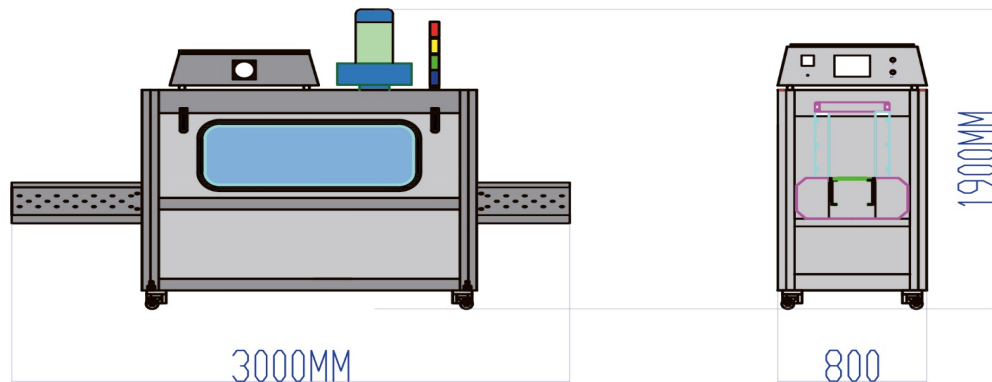

技术特点：

Technical Characteristics:

1、配置西门子工业计算机控制系统，可以对蒸汽流量、蒸汽温度进行数字设定与自动调节，具备蒸汽流量数控自动稳定系统。

1. Equipped with Siemens industrial computer control system, it can digitally set and automatically adjust steam flow and steam temperature, and has a numerical control automatic stabilization system for steam flow.

2、配置我公司研发的收缩包装专用的内置一体式蒸汽发生器，蒸汽输出稳定，工作时不储蓄压力，不属于压力容器，安全稳定可靠。

2. Equipped with the built-in integrated steam generator specially developed by our company for shrink packaging, the steam output is stable, the pressure is not stored during operation, and it is not a pressure vessel, which is safe, stable and reliable.

3、配置双层嵌套式钢化玻璃炉道，4段8区数字刻度流量调节系统，可以方便的记录不同产品的调节参数，并可以进行在线式可视化实时调节。

3. Equipped with double-layer nested tempered glass furnace channel and 4-section 8-zone digital scale flow regulation system, it can easily record the regulation parameters of different products and carry out online visual real-time regulation.

4、装备了出入口可调式卷闸气帘与变频调速排气系统，不仅可以控制进闸口的大小还可以精确调节进出气流，配合电脑系统精确控制收缩效果。

4. Equipped with inlet and outlet adjustable roller shutter air curtain and frequency conversion speed regulation exhaust system, it can not only control the size of inlet and outlet, but also accurately adjust the inlet and outlet air flow, and cooperate with the computer system to accurately control the shrinkage effect.

5、采用西门子、施耐德国际一线控制电器，严格按照国家安全标准与行业相关标准制造，具备多重安全保护措施，符合各项安全规定。

5. Siemens and Schneider International first-line control appliances are adopted, manufactured in strict accordance with national safety standards and relevant industrial standards, with multiple safety protection measures and in line with various safety regulations.



采用西门子工业计算机控制系统，各种工艺参数数字化自动控制，系统清晰明了，稳定高效，具备功率、温度数字化设定，蒸汽输出数控稳定系统。

Siemens industrial computer control system is adopted for digital automatic control of various process parameters. The system is clear, stable and efficient. It has digital setting of power and temperature and numerical control stability system of steam output.

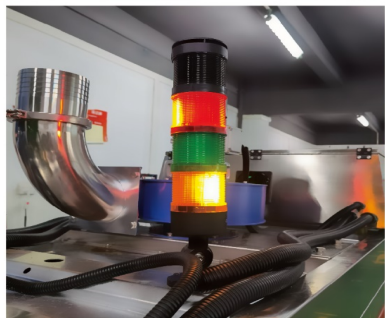

配备国际一线品牌高端电力仪表、总电源钥匙控制系统、前后安全急停装置与塔式信号报警器，高端标准化设计制造。

Equipped with international first-line brand high-end power instruments, main power key control system, front and rear safety emergency stop devices and tower signal alarms, high-end standardized design and manufacture.

进出口配置升降式卷闸帘，精确控制进出口气流，配合电脑参数灵活调节。

The inlet and outlet are equipped with lifting roller shutter to accurately control the air flow at the inlet and outlet and flexibly adjust the computer parameters.

304不锈钢输送带网带搭配不锈钢主动、从动传动轮，防腐、耐用、高效透气。

304 stainless steel conveyor belt with stainless steel driving and driven driving wheels is corrosion-resistant, durable, efficient and breathable.



双层嵌套式钢化玻璃收缩炉道、数字刻度气流调节阀门、手摇自锁升降系统、在线可视化系统设计，可以不停机的状态下可视化调节运行参数。

The design of double-layer nested tempered glass shrinkage furnace, digital scale air flow regulating valve, manual self-locking lifting system and online visualization system can visually adjust the operating parameters without shutdown.



内置多级过滤器，可有效拦截各种颗粒有机物、腐蚀性氯离子保护系统安全。

Built in multi-stage filter can effectively intercept various particulate organic matter and corrosive chlorine particles to protect the safety of the system.

ZS2535 蒸汽热收缩包装机单机应用工艺

The application process of the single machine of ZS2535 steam heat shrink packaging machine

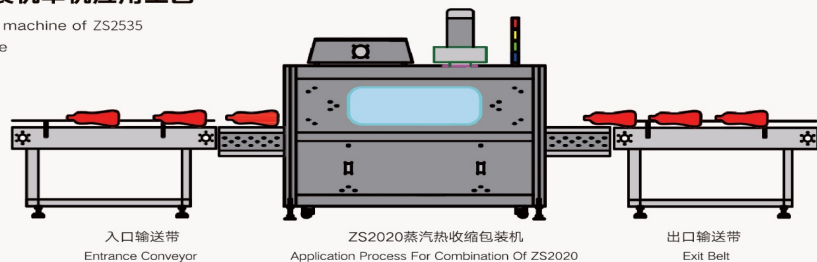

ZS2535 蒸汽热收缩包装机单机可组成手动套标收缩生产线，兼容大部分产品规格，内置蒸汽发生器，连接水电即可使用，可灵活移动，2米长的机身可以通过电梯快捷转运。设计遵从国家标准，美观大方、经济实惠。

The single machine of ZS2535 steam heat shrink packaging machine can form manual sleeve labeling shrinkage production line, and it is compatible with the most production specification. The machine is equipped with built-in steam generator, it can be directly used after being connected to water. And the machine can be flexibly moved. The length of 2m of the machine makes the machine quickly transported by elevator. The design complies with national standards, making elegant appearance and being economical and practical.

ZS2535 蒸汽热收缩包装机与自动吹干机组合应用工艺

Application process for combination of ZS2535 steam heat shrink packaging machine and automatic blow drying machine

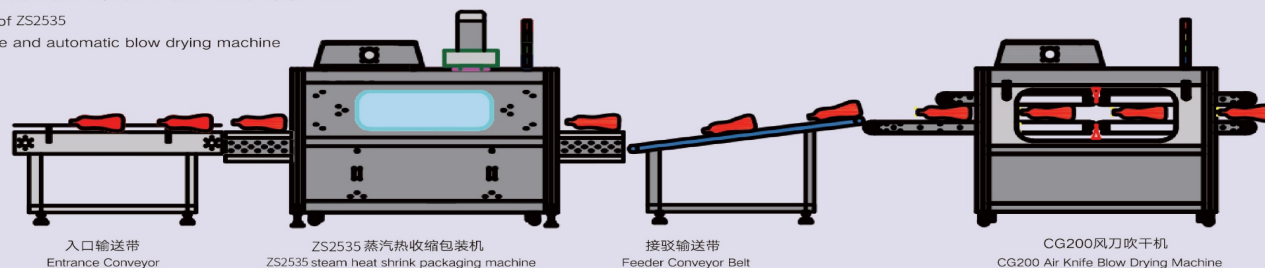

ZS2535 蒸汽热收缩包装机与CG200风刀吹干机组合使用，可以在产品收缩后自动流入吹干机，对产品表层水汽进行吹干，达到收缩后即刻装箱的目的，节约了人工擦干工序，解决了毛巾变脏晾干产品留下污渍问题。

When ZS2535 steam heat shrink packaging machine is combined with CG200 air knife blow drying machine for use, the products can be automatically flown into the blow drying machine after being shrunk, which dries the moisture on the surface of the product to achieve immediate packing after shrinking, to save the process of manual drying, which solves the problem of stain due to dirty towel.

ZS2535 蒸汽热收缩包装机与定位收缩机、自动吹干机组合应用工艺

Application process for combination of ZS2535 steam heat shrink packaging machine, positioning shrinker and automatic blow drying machine

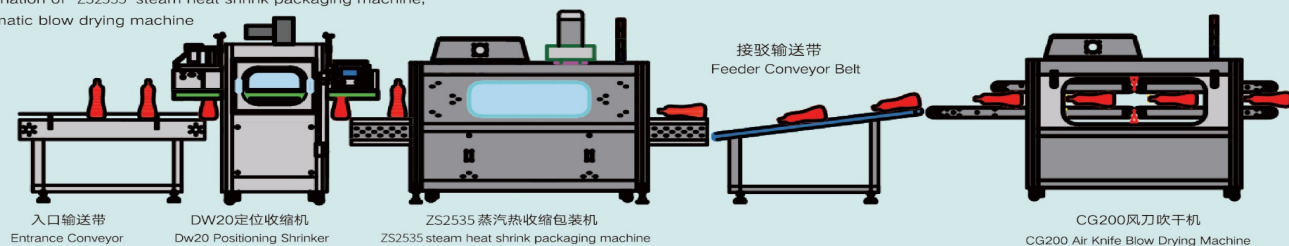

ZS2535 蒸汽热收缩包装机与DW20定位收缩机、CG200风刀吹干机组合使用，可以对需要包底的产品进行底部长度自动定位并预先收缩，然后流入 ZS2535 蒸汽热收缩包装机进行整体收缩，后面流入自动吹干机对产品表面水汽自动吹干，节约人工定位、吹干工序，提高生产效率，降低生产成本。

When ZS2535 steam heat shrink packaging machine is used with DW20 positioning shrinker, CG200 air knife blow drying machine, the bottom length of the product needs to be packed will be automatically positioned and shrunk in advance, and then, the products will be flown into ZS2535 steam heat shrink packaging machine for overall shrinking, and then, the products will be automatically flown to automatic blow drying machine to automatically dry the moisture on the surface, therefore, manual positioning and drying process can be saved to improve production efficiency and lower production costs.

ZS2535 蒸汽热收缩包装机与自动套标机、定位收缩机、自动吹干机组合应用工艺

The application process for combination of ZS2535 steam heat shrink packaging machine, automatic shrink sleeve labeling machine, positioning shrinker and automatic blow drying machine

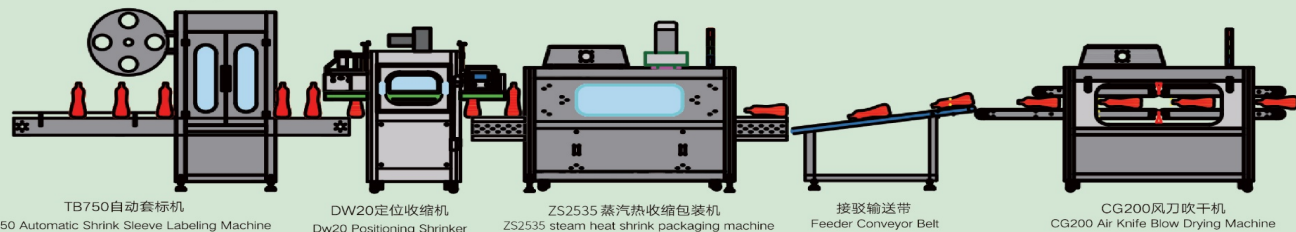

ZS2535 蒸汽热收缩包装机与TB750自动套标机、DW20定位收缩机、CG200自动吹干机配套使用可以实现：套标、包底定位、收缩、吹干的全自动生产。不需要包底定位的产品也可以去掉DW20定位收缩机，不需要吹干则去掉CG200风刀吹干机，用户根据需要自由搭配组合。

The combination of ZS2535 steam heat shrink packaging machine, TB750 automatic shrink sleeve labeling machine, DW20 positioning shrinker and CG200 automatic blow drying machine can achieve the full-automatic production of labelling, button positioning, shrinking and drying. For the products which do not need button positioning, DW20 positioning shrinker can be removed; for the products which do not need drying, CG200 air knife blow drying machine can be removed. Users are allowed to freely combine in accordance with the demands.

GT-ZS2535 蒸汽热收缩包装机配套设备简介

Introduction Of The Supporting Equipment Of GT-ZS2535 Steam Heat Shrink Packaging Machine

GT-DW20定位收缩包装机

Gt-dw20 Positioning Shrink Packaging Machine

DW20定位收缩包装机主要应用于产品收缩前底部标签高度自动定位，采用伺服数控系统精确控制标签超出瓶底的长度，并对定位部分进行与预先收缩固定位置。

DW20 positioning shrink packaging machine is mainly used for automatic positioning of the height of the label on the button before the products are shrunk. When the servo numerical control system is used, the length of the part exceeding the button of the label can be accurately controlled to conduct pre-shrinking to the fixing position in advance.



GT-CG200风刀吹干机

Gt-cg200 Air Knife Blow Drying Machine

CG200风刀吹干机主要应用于产品蒸汽收缩后表层水分的吹干，设备采用高压空气形成气刀高速吹脱产品表层的水珠来达到干燥的效果。

GT-CG200 air knife blow drying machine is mainly used to dry the moisture on the surface of the product after steam shrinking. The equipment uses high-pressure air to form an air knife to quickly blow off the drop of water on the surface of the products to achieve the effects of drying.



GT-TB750自动套标机

Gt-tb750 Automatic Shrink Sleeve Labeling Machine

TB750自动套标机主要应用于产品收缩膜标签自动套标，代替人工手动套标工序，可以非常高速高效的对各种产品进行全自动化的套标作业。

TB750 automatic shrink sleeve labeling machine is mainly used for the automatic labelling of the shrink film labels of the products. It can replace manual labelling process to complete the automatic labelling operation at a high speed.



部分客户案例

SELECTED CUSTOMER CASES



SHISEIDO
資生堂

PROYA
泊莱雅



中国印钞造币
中钞实业有限公司

LUX力士



蓝月亮



durex

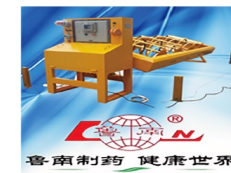

康商制药 健康世界
KEEPING THE WORLD HEALTHY